



## WashTec DogWash



### Join the Boom

With 4.8 million pet owners currently spending over \$2 billion on the care and welfare of their pets each year, there's never been a better time to join the industry that's growing at 10% every year. Already, hundreds of DogWash Systems are successfully operating throughout Australia, Europe and the US. Let us show you how you can benefit from a WashTec Dog Wash.

### Advantages

- Business all year round
- No more rainy days!
- 1 Year Warranty
- New Revenue
- Low cost, high profit
- Little maintenance required
- For dogs of all shapes & sizes



# Order Now: 1300 253 473



## WashTec DogWash

### The Cutest Way to Profit

A coin, token, or an optional note acceptor system consisting of various washing & drying functions will provide your customers with an easy, convenient, low cost way to wash their dogs clean. It's high grade Stainless Steel construction and low maintenance cost, ensures long life and on-going profit!

#### Features:

- Compact Modular Design
- Built-in Water Heater System
- Multifunction LCD Display
- Note acceptor
- Low Time Audible Warning
- Theft Proof locking System
- Vandal Resistant Stainless Steel
- Optional Dog Wash Vendor
- Shatter Proof Splash Screen

#### Wash Options:

- Wash Bay Disinfectant
- Silky Shampoo Wash
- Soft Conditioner Wash
- Fresh & Clean Rinse
- Flea Eradicator
- Blow Dry
- Turbo Bow Dry
- Optional Pause Button

### An Investors Best Friend

The DogWash can function as a completely 'stand alone' operation or integrated into your existing car wash, service station, caravan park pet store and anywhere dog lovers visit.

### Sit Back & Profit!

Many operations wash an average of 50-60 dogs each week. Each wash generates an average spend of \$10.50 but costs you only \$1.10. WashTec can provide you with a customised financial model showing you how payback on this investment is achievable in as little as 8 months.

#### Cost

\$1.10 per wash\*

#### Profit

\$9.40 per wash\*



Average wash - \$10.50 \*including finance

#### Technical Data

##### Electrical \*(ISR):

- 32 Amp single Phase supply with 2m tails

##### Water \*(ISR):

- 1/2" Supply at 4-6 bar

##### Drainage \*(ISR):

- 50mm drain for waste can be directed to sewer, triple interceptor or CPI device

##### Dimensions:

- 2062mm (W) x 600mm (D) x 1800mm (H) (with adjustable feet)

##### Material of Construction:

- 304 Grade Stainless Steel

##### Weight:

- 230kg

\* (ISR) Installation Services Required (Supplied by customer)

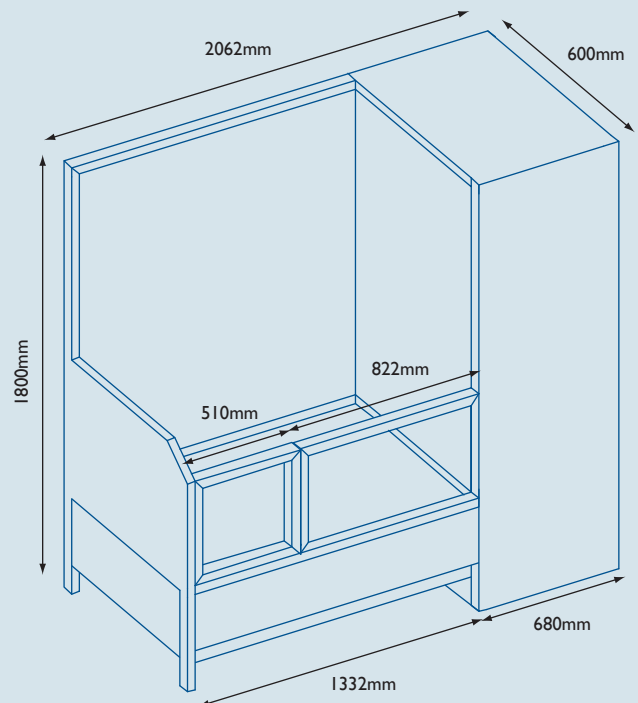

# Order Now: 1300 253 473